

# High-Stability I<sup>2</sup>C-Bus INTERFACE REAL TIME CLOCK MODULE

## RX - 8025 SA / NB

- Built-in 32.768 kHz crystal unit : Frequency adjusted for high accuracy ( $\pm 5 \times 10^{-6}$  /  $T_a = +25^\circ\text{C}$ )
- Interface Type : I<sup>2</sup>C-Bus Interface (400 kHz)
- Operating voltage range: 1.70 V to 5.5 V
- Wide Timekeeper voltage range : 1.15 V to 5.5 V
- Various detection Functions : Ex. Oscillation stop detection function
- Low backup current : 0.48  $\mu\text{A}$  / 3 V (Typ.)
- 32.768 kHz frequency output function : C-MOS output With Control Pin
- The various functions include full calendar, alarm, timer.

\* The I<sup>2</sup>C-Bus is a trademark of NXP Semiconductors

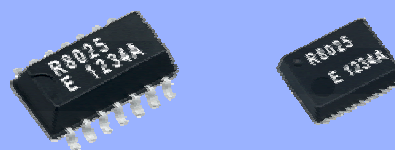

Actual size

RX-8025SA

RX-8025NB



### Block diagram

### Overview

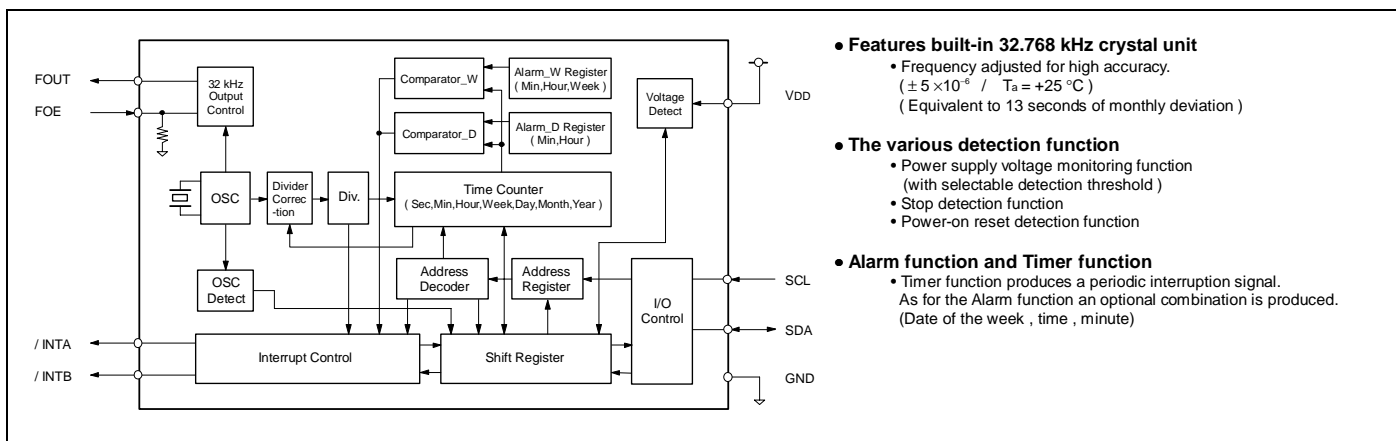

#### • Features built-in 32.768 kHz crystal unit

- Frequency adjusted for high accuracy. ( $\pm 5 \times 10^{-6}$  /  $T_a = +25^\circ\text{C}$ ) (Equivalent to 13 seconds of monthly deviation)

#### • The various detection function

- Power supply voltage monitoring function (with selectable detection threshold)
- Stop detection function
- Power-on reset detection function

#### • Alarm function and Timer function

- Timer function produces a periodic interruption signal. As for the Alarm function an optional combination is produced. (Date of the week , time , minute)

### Pin Function

### Terminal connection / External dimensions

(Unit:mm)

Signal Name	Input / output	Function																				
SCL	Input	Serial clock input pin																				
SDA	Bi-directional	Data input and output pin																				
FOUT	Output	32.768 kHz clock output pin with the output control function. (C-MOS)																				
FOE	Input	<table border="1"> <thead> <tr> <th>FOE input</th> <th>/CLEN1 bit</th> <th>/CLEN2 bit</th> <th>FOUT output</th> </tr> </thead> <tbody> <tr> <td>L</td> <td>X</td> <td>X</td> <td>OFF (LOW)</td> </tr> <tr> <td>0</td> <td>0</td> <td>0</td> <td>32.768 kHz</td> </tr> <tr> <td>1</td> <td>0</td> <td>1</td> <td>32.768 kHz</td> </tr> <tr> <td>1</td> <td>1</td> <td>1</td> <td>OFF (LOW)</td> </tr> </tbody> </table>	FOE input	/CLEN1 bit	/CLEN2 bit	FOUT output	L	X	X	OFF (LOW)	0	0	0	32.768 kHz	1	0	1	32.768 kHz	1	1	1	OFF (LOW)
		FOE input	/CLEN1 bit	/CLEN2 bit	FOUT output																	
		L	X	X	OFF (LOW)																	
		0	0	0	32.768 kHz																	
1	0	1	32.768 kHz																			
1	1	1	OFF (LOW)																			
/INTA	Output	Interrupt output A pin (N-ch open drain)																				
/INTB	Output	Interrupt output B pin (N-ch open drain)																				
TEST	—	* Used by the manufacture for testing. (Do not connect externally.)																				
VDD	—	Connected to a positive power supply.																				
GND	—	Connected to a ground.																				

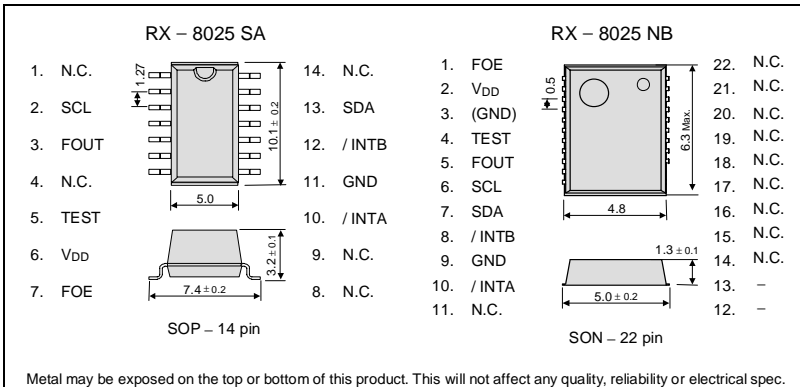

### Specifications (characteristics)

\* Refer to application manual for details.

#### ■ Recommended Operating Conditions

Item	Symbol	Condition	Min.	Typ.	Max.	Unit
Power voltage	VDD	—	1.7	3.0	5.5	V
Clock voltage	VCLK	—	1.15	3.0	5.5	V
Operating temperature	TOPR	—	-40	+25	+85	°C

#### ■ Frequency characteristics

Item	Symbol	Condition	Range	Unit
Frequency tolerance	$\Delta f / f$	$T_a = +25^\circ\text{C}$ VDD = 3.0 V	AA: $5 \pm 5^{*1}$ AC: $0 \pm 5^{*2}$	$\times 10^{-6}$
Oscillation start-up time	t <sub>STA</sub>	$T_a = +25^\circ\text{C}$ VDD = 2.0 V	1 Max.	s
Frequency voltage characteristics	f / V	$T_a = +25^\circ\text{C}$ VDD = 2.0 V to 5.5 V	$\pm 1$ Max.	$\times 10^{-6}$

\*1) \*2) Equivalent to 13 seconds of monthly deviation (excluding offset).

#### ■ Current consumption characteristics

$T_a = -40^\circ\text{C}$  to  $+85^\circ\text{C}$

Item	Symbol	Condition	Min.	Typ.	Max.	Unit
Current Consumption	I <sub>BK</sub>	f <sub>SCL</sub> = 0Hz FOE = GND FOUT ; output OFF (LOW)	VDD = 5 V	0.60	1.80	$\mu\text{A}$
		VDD = 3 V	0.48	1.20		
Current Consumption	I <sub>32k</sub>	f <sub>SCL</sub> = 0Hz VDD, FOE = 5.5 V FOUT ; output ON (Output=OPEN; CL = 0 pF)	VDD = 5.5 V	3.0	6.5	$\mu\text{A}$
		VDD = 3 V	3.0	6.5		

#### ■ Power supply detection voltage

$T_a = -30^\circ\text{C}$  to  $+70^\circ\text{C}$

Item	Symbol	Condition	Min.	Typ.	Max.	Unit
High-voltage mode	VDETH	VDD pin	1.90	2.10	2.30	V
Low-voltage mode	VDETL	VDD pin	1.15	1.30	1.45	V